

Türblattaußenmaß überfälzte Türen DIN 18101 Türblattaußenmaß stumpfe Türen DIN 18101

(alle angegebenen Maße in mm)

RRB		RRH		RNB		RNH		FMB		FMH		Einfachfalz		Doppelfalz		überfälzt		stumpf	
RRB	RRH	RNB	RNH	FMB	FMH	LDB	LDH	LDB	LDH	LDB	LDH	überfälzt	überfälzt	überfälzt	überfälzt	stumpf	stumpf	stumpf	stumpf
625	1875	635	1880	591	1858	561	1843	531	1828	610	1860	584	1847						
750	1875	760	1880	716	1858	686	1843	656	1828	735	1860	709	1847						
875	1875	885	1880	841	1858	811	1843	781	1828	860	1860	834	1847						
1000	1875	1010	1880	966	1858	936	1843	906	1828	985	1860	959	1847						
1125	1875	1135	1880	1091	1858	1061	1843	1031	1828	1110	1860	1084	1847						
1250	1875	1260	1880	1216	1858	1186	1843	1156	1828	1235	1860	1209	1847						
625	2000	635	2005	591	1983	561	1968	531	1953	610	1985	584	1972						
750	2000	760	2005	716	1983	686	1968	656	1953	735	1985	709	1972						
875	2000	885	2005	841	1983	811	1968	781	1953	860	1985	834	1972						
1000	2000	1010	2005	966	1983	936	1968	906	1953	985	1985	959	1972						
1125	2000	1135	2005	1091	1983	1061	1968	1031	1953	1110	1985	1084	1972						
1250	2000	1260	2005	1216	1983	1186	1968	1156	1953	1235	1985	1209	1972						
625	2125	635	2130	591	2108	561	2093	531	2078	610	2110	584	2097						
750	2125	760	2130	716	2108	686	2093	656	2078	735	2110	709	2097						
875	2125	885	2130	841	2108	811	2093	781	2078	860	2110	834	2097						
1000	2125	1010	2130	966	2108	936	2093	906	2078	985	2110	959	2097						
1125	2125	1135	2130	1091	2108	1061	2093	1031	2078	1110	2110	1084	2097						
1250	2125	1260	2130	1216	2108	1186	2093	1156	2078	1235	2110	1209	2097						
625	2250	635	2255	591	2233	561	2218	531	2203	610	2235	584	2222						
750	2250	760	2255	716	2233	686	2218	656	2203	735	2235	709	2222						
875	2250	885	2255	841	2233	811	2218	781	2203	860	2235	834	2222						
1000	2250	1010	2255	966	2233	936	2218	906	2203	985	2235	959	2222						
1125	2250	1135	2255	1091	2233	1061	2218	1031	2203	1110	2235	1084	2222						
1250	2250	1260	2255	1216	2233	1186	2218	1156	2203	1235	2235	1209	2222						

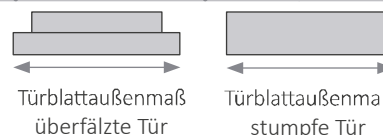

Sonderzarge in Anlehnung an DIN 18111

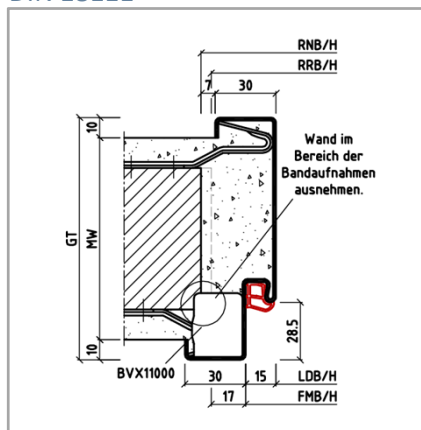

Duo15Z, 2-schalig

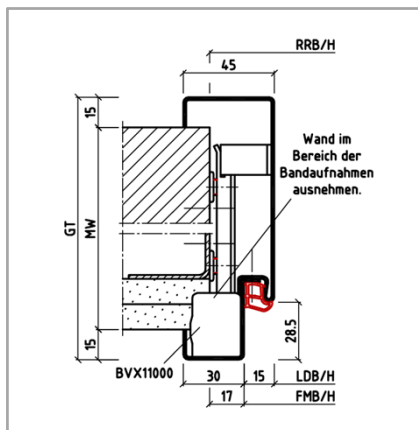

Das Rohbaurichtmaß ist das Idealmaß zum Einbau der Duo 15Z, bei Normöffnungen können Normtürblätter in die Stahlzarge eingesetzt werden!

Legende:

- RRB/H: Rohbau Richtmaß Breite/Höhe
- RNB/H: Rohbau Nennmaß Breite/Höhe
- FMB/H: Falzmaß Breite/Höhe
- LDB/H: Lichte Durchgangs Breite/Höhe
- GT: Gesamttiefe
- MW: Maulweite